

BALANCED PRESSURE
THERMOSTATIC STEAM TRAP

DX1

USER'S MANUAL



 **MIYAWAKI INC.**

SAFETY GUIDE

The Model DX1 is a balanced pressure thermostatic steam trap equipped with a membrane capsule (thermo element).

The steam trap discharges the condensate automatically at a temperature 5°C/9°F (capsule C) below saturation temperature.

In order to get maximum benefit from this product, be sure to read this manual before installing it.

The following warnings and cautions are shown at appropriate places in this manual.



Failure to observe this type of precaution may lead to serious injury or death.



Failure to follow this type of precaution can lead to injury or damage to equipment and property.

Table of Contents

1	SPECIFICATIONS AND MARKINGS	1
2	CONSTRUCTION DETAILS	2
3	INSTALLATION	2
4	OPERATION	3
5	MAINTENANCE	4
6	TROUBLESHOOTING	6
7	WARRANTY	7
8	SERIAL NUMBER (S. No.) DESIGNATION	8
9	GUIDANCE FOR READING SPECIAL PRODUCT NAME	9

1 SPECIFICATIONS AND MARKINGS



WARNING

Be sure not to use this product at higher pressures than the specified maximum allowable pressure (PMA) or at temperatures higher than the specified maximum allowable temperature (TMA).

Check the operating characteristics to avoid misuse of the product.

- 1) Maximum allowable pressure (PMA): 0.5 MPa (73 psig)
 - 2) Maximum allowable temperature (TMA): 160 °C (320 °F)
 - 3) Maximum operating pressure (PMO): DX1-5 - 0.5 MPa (73 psig)
(Shown as MAX.P. on the name plate) DX1R-5 - 0.5 MPa (73 psig)
 - 4) Maximum operating temperature (TMO): 160 °C (320 °F)
(Shown as Max.T. on the name plate)
 - 5) Size: 38 mm (ISO 2852)
 - 6) Year of production: The two leftmost digits in the four-digit or nine-digit "S. No." are the last two digits of the year of production.
 - 7) Flow direction: Shown by an arrow
 - 8) Body material: Stainless steel SUS316
 - 9) Model: Showing the product model name
- Some pictures and illustrations in this manual are examples of DX1 models. For more details regarding dimensions and other specifications, please refer to the catalog.

The model DX1 fully complies with the requirements of the European Pressure Equipment Directive 2014/68/EU. It is classified according to Article 4, Section 3 of the PED, which does not allow to bear the CE marking.

2 CONSTRUCTION DETAILS

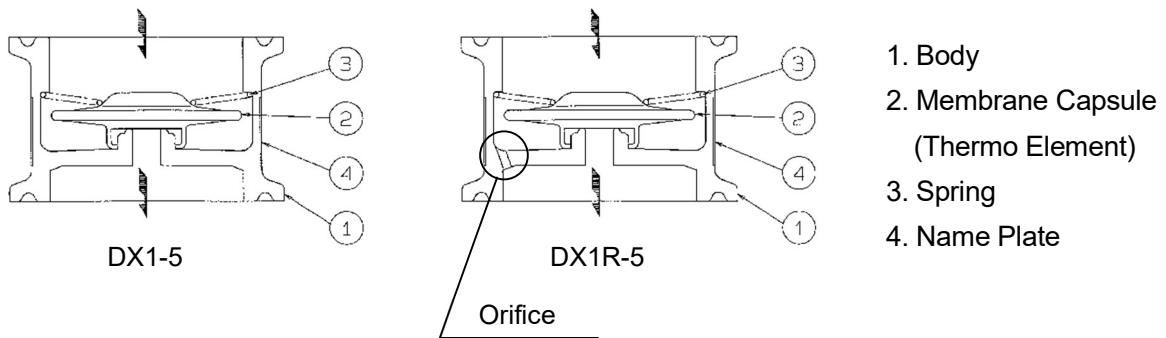

3 INSTALLATION



WARNING

Pay very careful attention when working in hazardous environments. There is a risk of explosion and the possibility of dangerous gases leaking. Always check whether the pipeline contains flammable, high pressure or high temperature materials before starting to work.

- Make sure that isolation valves are installed on both the upstream and downstream lines.



CAUTION

Before installing the product, open both isolation valves and the bypass valve, if one exists, to blow out any debris or dirt inside the pipeline. After blowing out the line, before starting to work, close the isolation valves and allow time for the temperature to drop to a safe working temperature.

When installing the product, be sure to leave clearance for maintaining it.

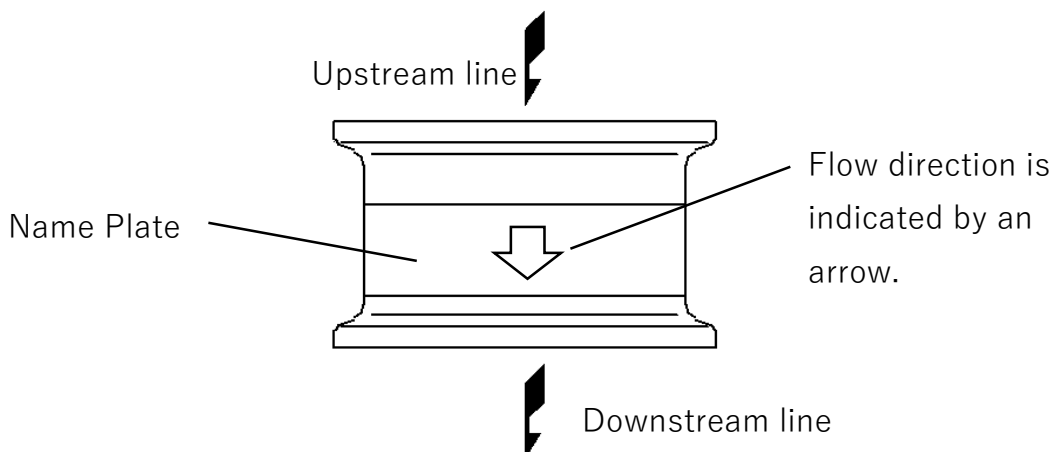

- 1) Remove the protective caps covering both connections.
- 2) Check the flow direction indicated on the name plate.
- 3) The DX1 can be used for both horizontal and vertical lines. However, when installing DX1R-5 in the horizontal position, the body with the "TOP" mark must be facing up.
- 4) Open the isolation valve on the upstream line slowly and make sure the product works normally.

4 OPERATION



CAUTION

Before starting operation, open the bypass valve or blow valve completely and blow off the scale in the piping.

4.1 Operation procedure

- 1) After blowing off the scale from the piping, close the bypass valve or blow valve.
- 2) Open the stop valve on the trap outlet side.
- 3) Open the stop valve on the trap inlet side.

4.2 Stop procedure

- 1) Close the stop valve on the trap inlet side.
- 2) Close the stop valve on the trap outlet side.

* When stopping for a long time, completely drain the condensate from the piping and trap and close the valves before and after the trap.

5 MAINTENANCE



WARNING

- Before removing the trap from the pipe or disassembling it, be sure to close the isolation valves. Then, release the residual pressure from the trap body (make sure that the pressure in the main body is equal to the atmospheric pressure). After it has fully cooled down (after the temperature of the main body has reached ambient temperature), confirm for safe conditions and then begin to work.
- Even when the isolation valves are closed, there may be residual internal pressure due to leaks from the isolation valves. Therefore, be very careful.



CAUTION

- When replacing parts, make sure the replacement parts are supplied by MIYAWAKI.

The performance of steam traps deteriorates gradually over time due to wear, corrosion or dirt accumulating around the valve and the valve seat. Please conduct periodic diagnosis of traps in order to keep steam control systems and equipment working well.

5.1 Tools for Diagnosis Steam Traps

■ Dr. Trap

Dr. Trap is a sophisticated steam trap management system for diagnosing steam traps automatically by measuring the vibration and temperature of the steam trap. Survey results are stored in the testing equipment and transferred to a steam trap analysis software. The software aggregates and analyses steam trap survey data, identifying faulty steam traps, providing steam loss and financial loss data, estimating CO₂ emissions corresponding to leaking steam traps and providing many other analyze possibilities to manage the steam trap population easily.

■ Dr. Trap Jr.

Dr. Trap Jr. is an inexpensive and easily to handle steam trap diagnostic system consisting of an ultrasonic checker, temperature probe and a sophisticated analysis software. The software allows to determine the condition of a steam trap, to estimate steam and financial losses and the related CO₂ emissions.

For more details, please, check our homepage:

<https://www.miyawaki.net/en/products/steam-trap-management-system>

or ask our local representative.

5.2 Repairs

When a trap fails, it is necessary to clean the internal parts and to replace damaged parts. Take the failed trap apart following the steps below.

5.2.1 Disassembling the trap

- 1) Take out the membrane capsule (thermo element) (2) by removing the spring (3).
- 2) Inspect the valve seat of the body (1), the membrane capsule (thermo element) (2) and the spring (3). Clean for any debris found.



CAUTION

Clean the body with care not to damage the sealing surface. Scratches on the sealing surface may cause steam leakage.

Take appropriate measures according to “6. Troubleshooting”. After cleaning the trap and replacing damaged parts, reassemble the parts in reverse order as follows.

5.2.2 Reassembling the trap

- 1) Insert the membrane capsule (thermo element) (2) into the body (1).
- 2) Insert the spring (3) in the body (1) to lock the membrane capsule (thermo element) (2).

6 TROUBLESHOOTING

Problem	Possible cause	Solution
Steam leaks or blows through.	Too high operating pressure.	Check operating conditions. Reduce the inlet pressure or change to another trap with higher pressure capability.
	A foreign object is caught between the valve of the membrane capsule (thermo element) (2) and the valve seat of the body.	Disassemble and clean the membrane capsule (thermo element) (2) and valve seat.
	The valve of the membrane capsule (thermo element) (2) and/or the valve seat are damaged.	If the valve seat is damaged replace the trap with a new one. If the valve of the membrane capsule (thermo element) (2) is damaged replace the capsule with a new one.
	The membrane capsule (thermo element) (2) is damaged.	Replace the membrane capsule (thermo element) (2).
Although working, the temperature inside the equipment cannot increase	Trap is installed in wrong direction.	Reinstall the trap in the proper direction, arrow on the body pointing in the direction of flow.
	Steam pressure is too low.	Increase the steam pressure.
	Steam flows through, but excessive built-up of condensate in the pipeline caused the trap to remain closed.	Re-position pipe to allow the condensate to flow down into the trap's inlet easily.
	Air is accumulated inside the equipment.	Check the equipment and conditions and make improvements.
	Insufficient condensate discharged.	Change trap with one that has a bigger capacity.

7 WARRANTY

7.1 Warranty period

The warranty period is 18 months after shipment or 12 months after installation, whichever occurs first.

7.2 Details of the warranty

If the product stops working correctly within the warranty period, we will repair or replace the product free of charge if the cause of the trouble is not one of the following items.

- 1) The precautions described in this manual were not observed.
- 2) User's errors or mistakes such as an inappropriate installation or incorrect handling, or an excessively large impact caused by dropping
- 3) Problems caused by devices or equipment other than MIYAWAKI's, or a disallowed use environment
- 4) When a repair or modification has been performed by anyone other than MIYAWAKI or people who are authorized to make such repairs
- 5) Intrusion of salt or other substances that promote significant rust or corrosion or problems from fluids that contain the same substances
- 6) Consumable parts such as Packing, Gasket, O-ring, Diaphragm, etc.
- 7) Attachment or accumulation of foreign matter in the pipe, such as dust and scale
- 8) Problems from fires, natural disasters, or other force majeure which is not MIYAWAKI's responsibility

7.3 Warranty limitation

The remedy available under the warranty shall not exceed the sales price of the products delivered, for any cause whatsoever.

8 SERIAL NUMBER (S. No.) DESIGNATION

The following 4-digit or 9-digit “S. No.” is displayed on the product.

- For 4-digit display

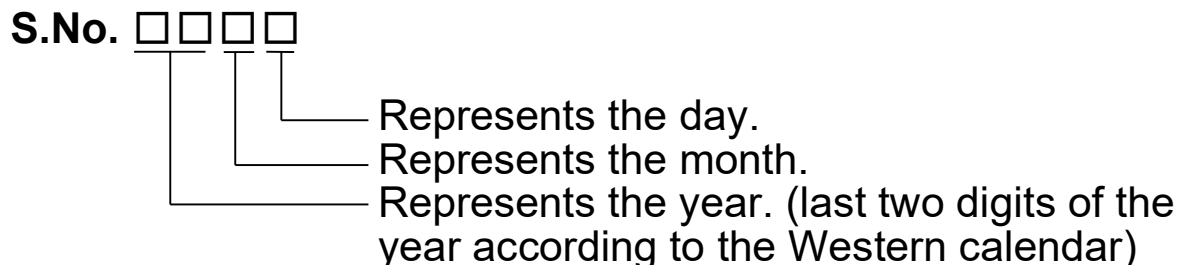

Example of serial number designation

1 7 1 1 → Jan.1, 2017

2 9 X M → Oct. 21, 2029

- For 9-digit display

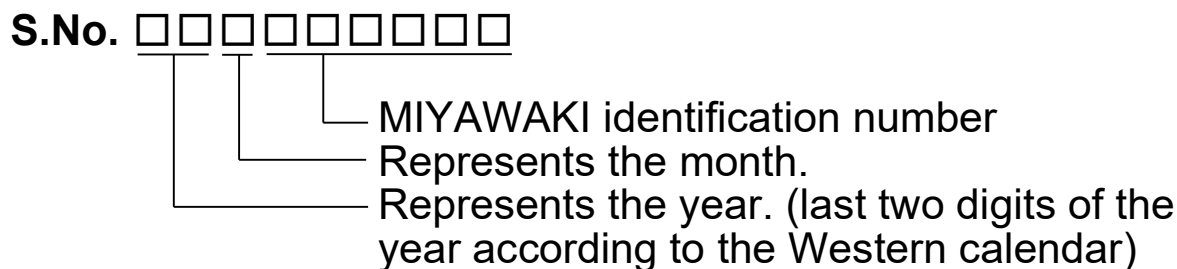

Example of serial number designation

1 7 1 1 2 C 0 2 0 → Jan., 2017

2 9 X 0 5 M 0 5 0 → Oct., 2029

Month designation system

Month	1	2	3	4	5	6	7	8	9	10	11	12
Symbol	1	2	3	4	5	6	7	8	9	X	Y	Z

Day designation system

Day	1	2	3	4	5	6	7	8	9	10	11	12
Symbol	1	2	3	4	5	6	7	8	9	A	B	C

Day	13	14	15	16	17	18	19	20	21	22	23	24
Symbol	D	E	F	G	H	J	K	L	M	N	O	P

Day	25	26	27	28	29	30	31
Symbol	Q	R	S	T	U	V	W

9 GUIDANCE FOR READING SPECIAL PRODUCT NAME

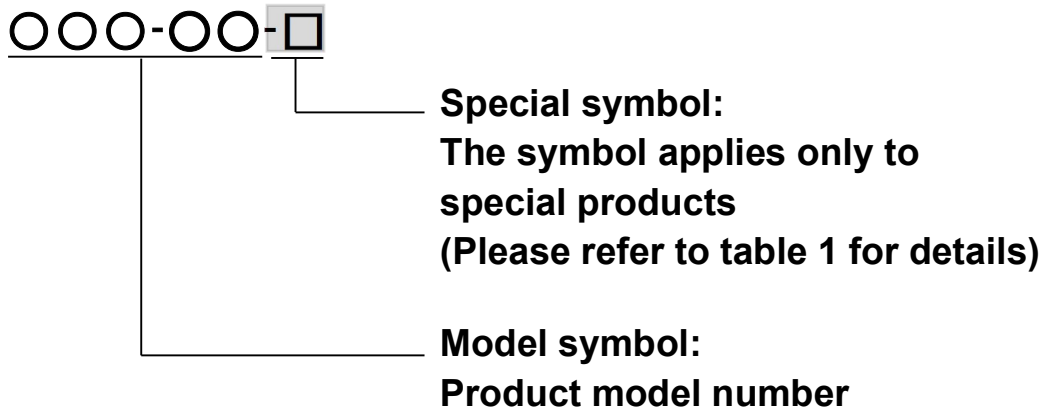

Table 1 Symbol description

Suffix	Special contents
A	Trap for high-pressure gas installed property (only for Gas Trap)
C	Blow valve attached
K	Change of gasket
L	Special face to face dimension
M	Change of parts material
P, T	Change of operating pressure, temperature, condensate capacity, etc
R	Change of screen mesh
V	Change of air vent
X	Other than mentioned above or complex of special contents above

-
- お買い上げの製品及びこの取扱説明書内容についてのご質問は下記にお問い合わせください。また、この取扱説明書を紛失したり、汚損により読めなくなった場合は、同じく下記へご請求ください。
 - 特殊仕様の製品については、取扱説明書の内容と一部異なる場合があります。特殊仕様に関する取扱説明書内容についてのご質問は、お買い上げ頂いた販売店若しくは最寄の弊社ミヤワキまでお問い合わせください。
 - 外観及び仕様などは、製品改良のため予告なしに一部変更させて頂くことがあります。
-
- For any questions about the product that you purchased or about the details in this user's manual, please contact the following.
 - © 2020 MIYAWAKI INC.
This user's manual may not be reproduced or copied in whole or in part, without the written consent of MIYAWAKI INC.
 - Some special specifications of the product you have, may found to be different from the ones in the user's manual. If you have any question, please contact MIYAWAKI, our local authorized agent, or the company where you purchased the product.
 - In the interest of the development and improvement of our products, MIYAWAKI Inc. reserves the right to change the specification of the products without prior notice.
-



お問い合わせ窓口

製品の使い方やアフターサポートなど、製品に関するお問い合わせは、右のQRコードから、最寄りの弊社事業所までご連絡ください。弊社事業所一覧(連絡先)は右のQRコードをスマートフォン、携帯電話等で読み取っていただくことでアクセスできます。



本社・工場

〒532-0021 大阪市淀川区田川北 2-1-30

Tel : 06-6302-5531(代)

www.miyawaki-inc.com



MIYAWAKI INC.

INTERNATIONAL SALES DEPT.

2-1-30, Tagawakita, Yodogawa-ku, Osaka, 532-0021, Japan

Tel: +81-6-6302-5549

www.miyawaki.net e-mail: export@miyawaki-inc.co.jp

EU Importer and Authorized representative:



MIYAWAKI GmbH

Birnbaumsmühle 65, 15234 Frankfurt (Oder), Germany

Tel: +49-335-4007-0097

www.miyawaki.net e-mail: info@miyawaki.de

China Importer and Authorized representative:



MIYAWAKI WEST Co., Ltd.

Room 1705, No.1, Building No.311, Yanxin Road, Huishan Economic Development Zone, Wuxi, Jiangsu, China

Tel: +86-510-8359-5125

www.miyawaki-inc.com.cn e-mail: mywkwest@miyawaki-inc.com.cn

808103-04 2003

DX1