

# DL1

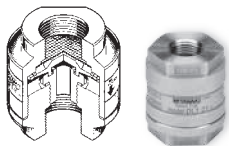

# DX1



# DF1

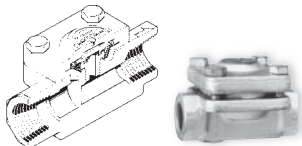

Dimensions

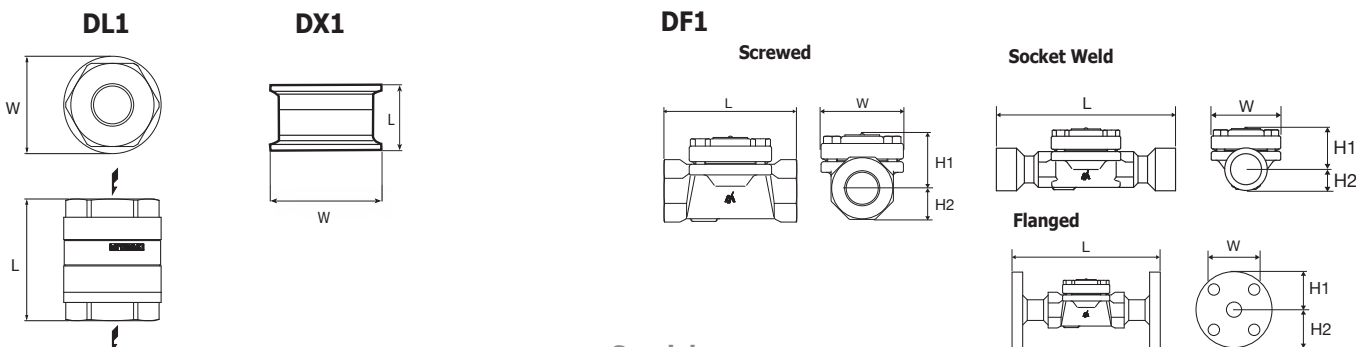

Special face-to-face dimensions available.

Capacity Chart DL1, DF1

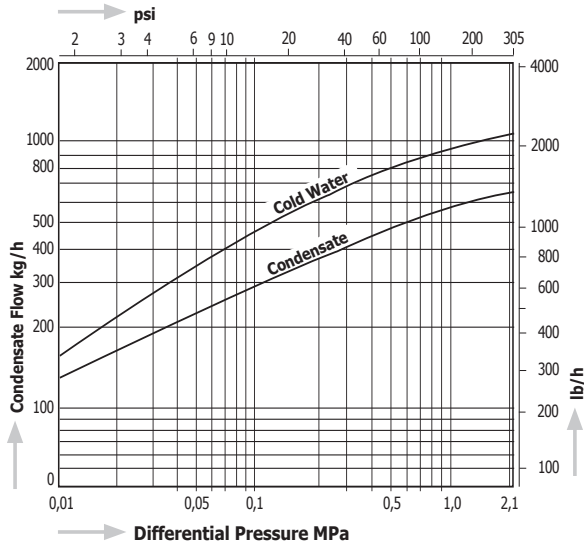

Capacity Chart DX1

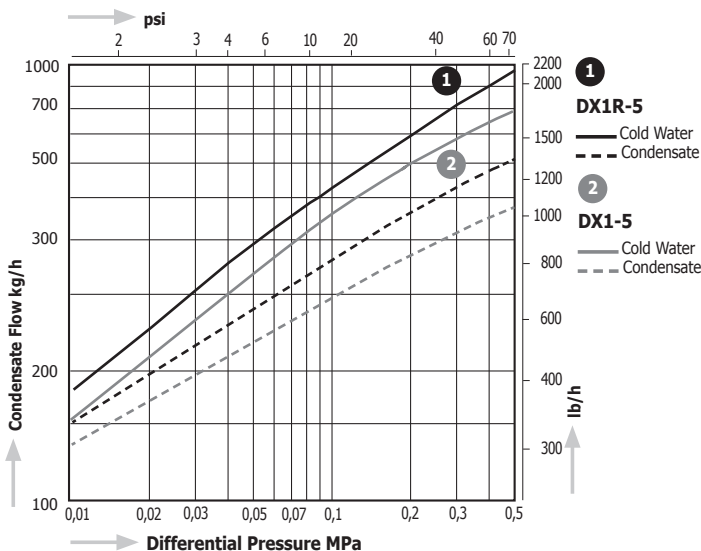

Model	Connections	Size	Max. Operating Pressure		Max. Operating Temperature		Dimensions (mm)				Dimensions (in)				Body Material	Weight						
			MPa	psig	°C	°F	L	H1	H2	W	L	H1	H2	W		kg	lb					
DL1-21H DL1-21L	Screwed Rc, NPT	1/4"	2,1	305	220	428	60	-	-	48	2.4	-	-	1.9	Stainless Steel SCS13	0,7	1.5					
		3/8"																				
		1/2"																				
		3/4"																				
DL1-10C	Screwed Rc, NPT	1/4"	1,0	145	220	428	60	-	-	48	2.4	-	-	1.9	Stainless Steel SCS13	0,7	1.5					
		3/8"																				
		1/2"																				
		3/4"																				
DX1-5 DX1R-5	Tri-Clamp	38 mm	0,5	72.5	160	320	30	-	-	51	1.2	-	-	2.0	Stainless Steel SUS316	0,18	0.4					
		1"																				
DF1-21H DF1-21L	Screwed Rc, NPT	1/2"	2,1	305	235	455	85	36	18	62	3.4	1.4	0.7	2.4	Forged Steel A105	1,0	2.2					
		3/4"					100	40	23		3.9	1.6	0.9			1,3	2.9					
		1"					160	36	18		62	6.3	1.4			0.7	2.4	1,4	3.1			
DF1-21HW DF1-21LW	Socket Weld JIS, ASME, DIN	1/2"	2,1	305	235	455	175	36	18	62	6.9	1.4	0.7	2.4	Forged Steel A105	2,1	4.6					
		3/4"									195	40	23			7.7	1.6	0.9	2.4	3,3	7.3	
		1"									215	40	23			8.5	1.6	0.9	2.4	4,0	8.8	
DF1-21HF DF1-21LF	Flanged JIS, ASME 150, 300 lb	1/2"	2,1	305	235	455	150	36	18	62	5.9	1.4	0.7	2.4	Forged Steel A105	2,3	5.0					
		3/4"									150	36	18			62	5.9	1.4	0.7	2.4	3,6	7.9
	1"	150									36	18	62			6.3	1.4	0.7	2.4	4,3	9.5	
	DN15	150									36	18	62			6.3	1.4	0.7	2.4	4,3	9.5	
DF1-21HF DF1-21LF	Flanged DIN PN40	DN20	2,1	305	235	455	150	36	18	62	5.9	1.4	0.7	2.4	Forged Steel A105	2,3	5.0					
		DN25									150	36	18			62	6.3	1.4	0.7	2.4	3,6	7.9
		DN25									150	36	18			62	6.3	1.4	0.7	2.4	4,3	9.5

DX1R-5 – Type with bypass orifice to prevent residue of condensate in steam traps.